

Unit and Clamping Element Catalogue

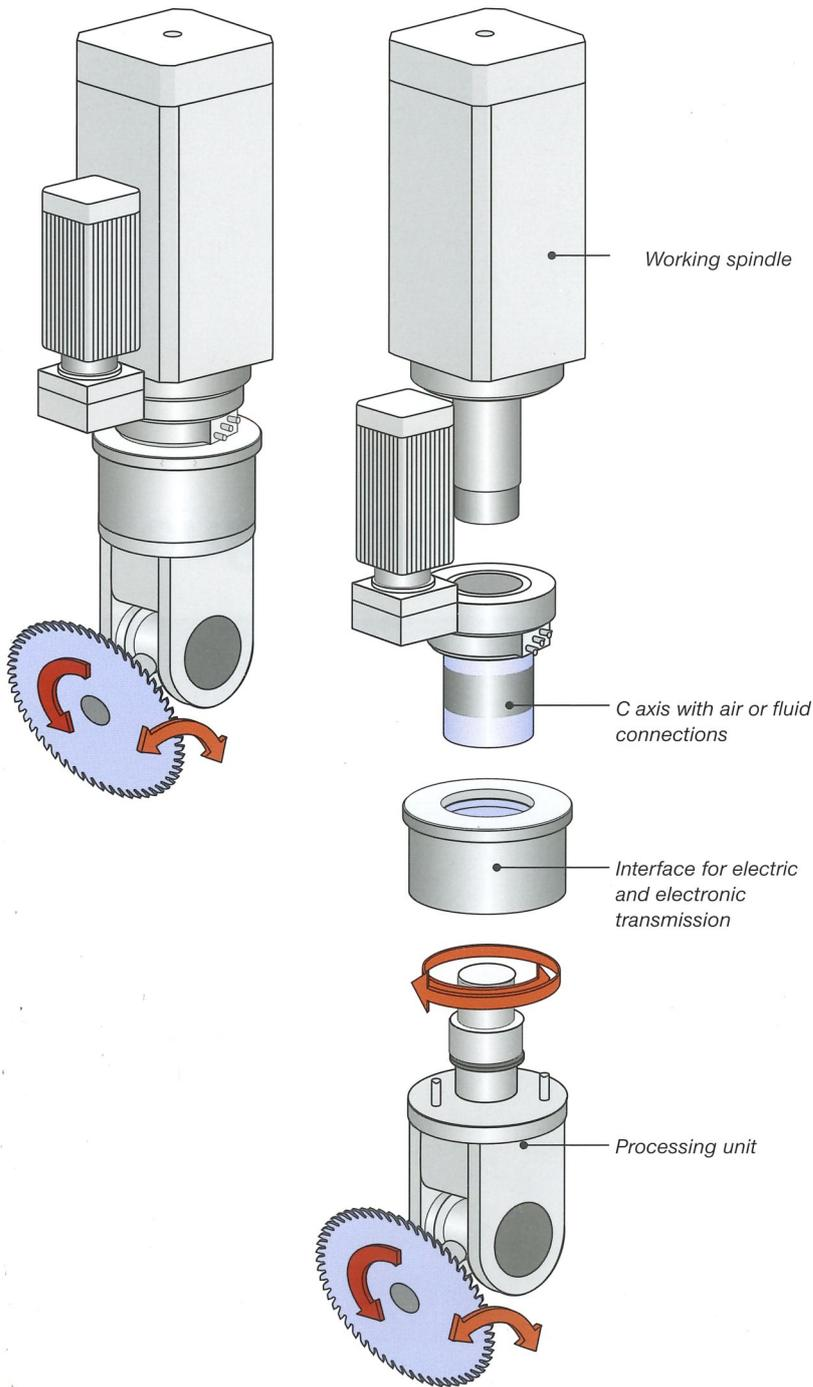

Optimat | profi line | power line

Sophisticated technology to address complex processing needs



Windows today, doors tomorrow, furniture elements the day after... The outstanding flexibility of Homag processing centres and routers with their versatile processing units offers practically unlimited scope for production.

The range of modular units

The units required for any specific processing operation are fully automatically exchange mounted from a tool changer system into the machine's working spindle. The C axis permits them to be swivelled around a full 0 to 360° circle. Depending on the application, they are also equipped with pneumatic or electronic connections. A selection of the most important units are presented on the following pages. If the one you require for a specific task is not amongst them, simply ask us. The range of units is continuously updated and upgraded, and the complete selection is not illustrated here.

Working spindle

External drive of 7.5, 14.5 or 21 kW (10,0/19,5 or 28 HP) via the working spindle

C axis

C axis for rotary movement (0-360° rotation)

Pneumatics

Compressed air supply

Electrics/electronics

Self drive with 220 V and control with 24 V

Open interface

360° gluing unit

Trimming tool uses drive system

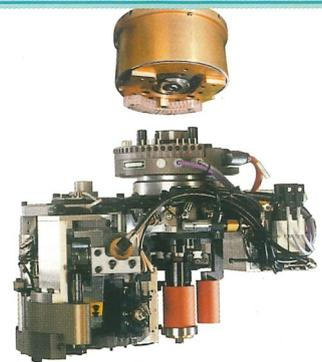

Traced flush trimming unit uses drive, C-axis and pneumatic interface

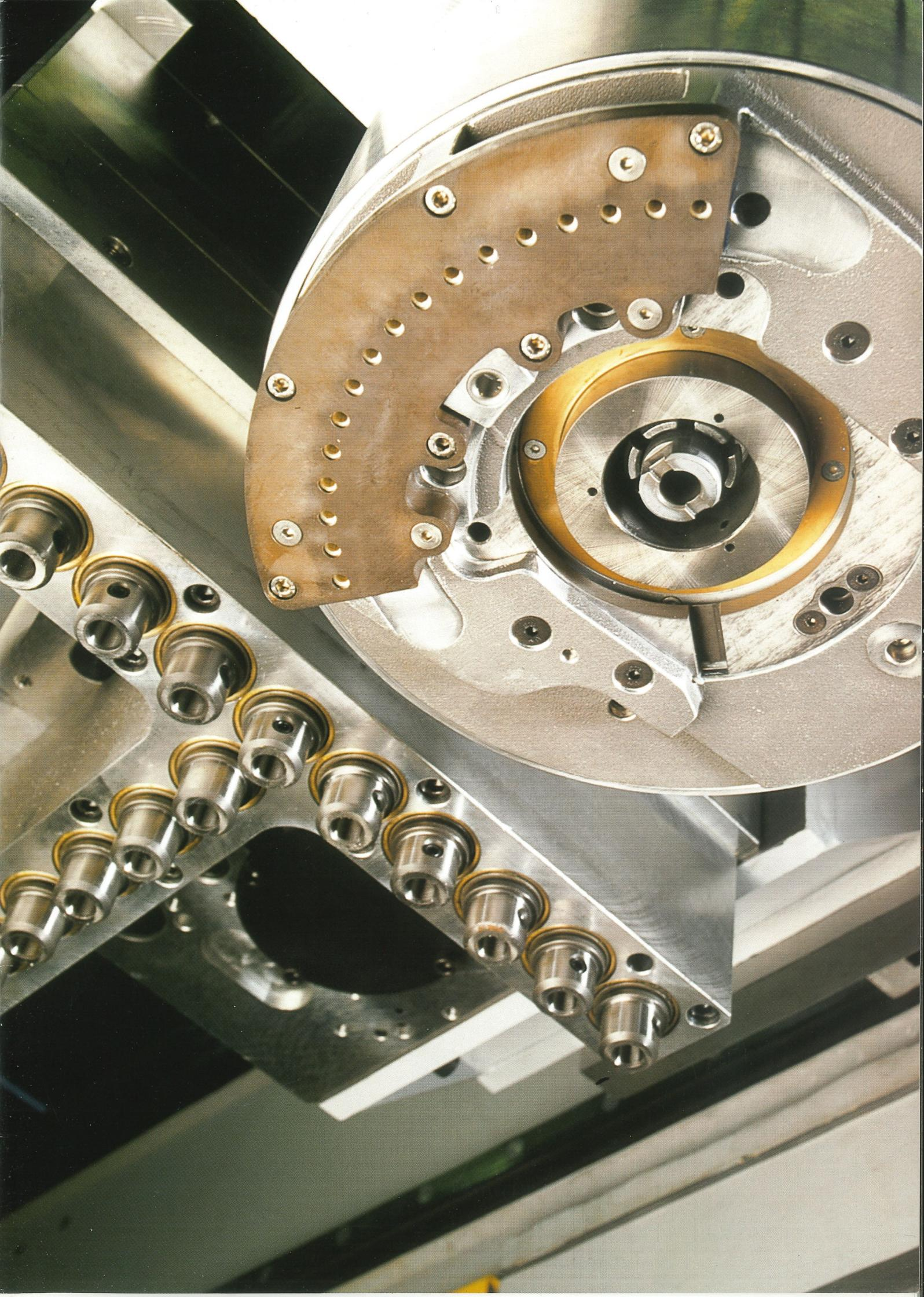

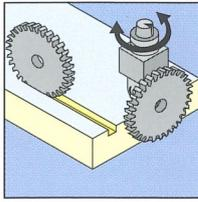
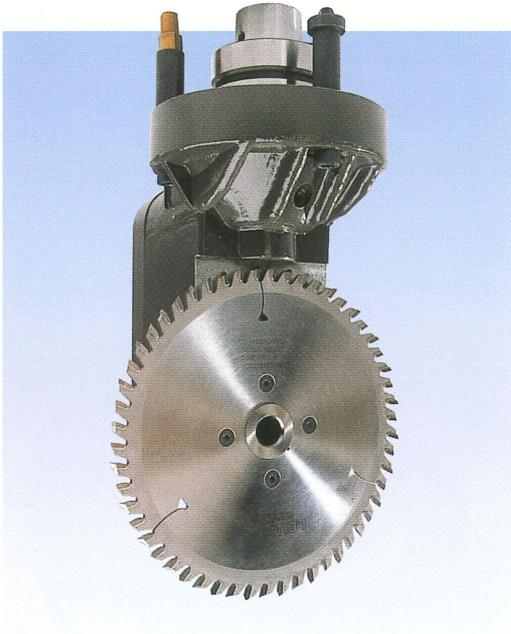

Sawing and snipping unit

The controlled C axis permits sizing, grooving, snipping and separating cuts at an arbitrary angle, and also saws recesses and notches. (Special version has a maximum cutting height of 110 mm).

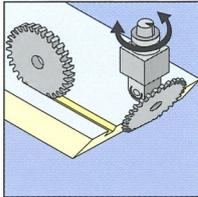

Swivel-action sawing / drilling unit

For sawing cuts and boreholes at any angle between 0° (vertical) and 90° (horizontal). This also opens up scope for precise-fitting cuts. Applications: Mitre cuts, hinge hole drilling on doors etc.

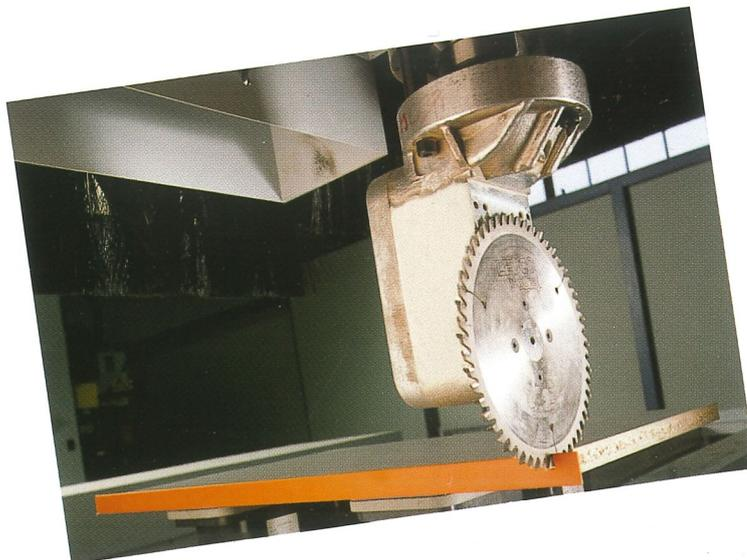
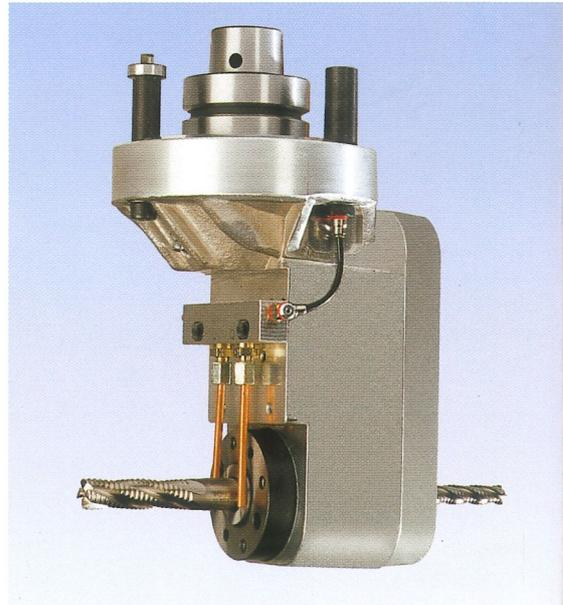

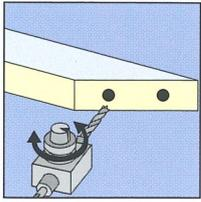

2-spindle sawing / drilling unit

For horizontal drilling work and light trimming work, e.g. grooving or oblong holes. Facility for one-sided equipment as a sawing unit. Saw blade diameter max. 240 mm.

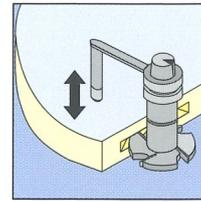

Vertical routing unit with tracing skid

For routing work in the panel surface or on profiles, e.g. precise-fitting grooves for joining kitchen worktops. Processing operations on workpieces with overhanging edge are also possible. Also available with tracing from below.

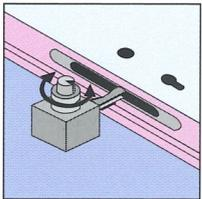

2-spindle lock case trimming unit

For trimming work such as lock cases and lock face plates on doors, for drilling work with integrated air jet for chip removal and two-sided spindle outlet for two tools.

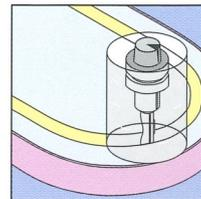

Vertical routing unit with tracing drum

For grooving and engraving work in the panel surface with surface tracing. Tracing drum with integrated air jet device.

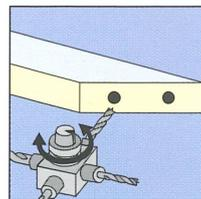
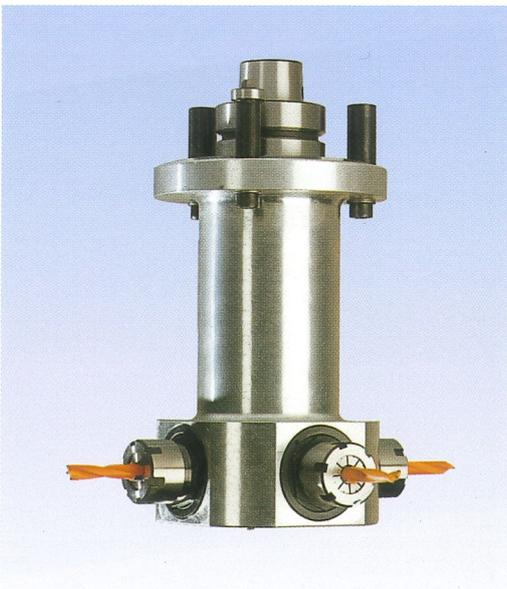

4-spindle horizontal trimming unit

For drilling and trimming work, e.g. on grooves, oblong holes, notches and trimming of edges at any angle.

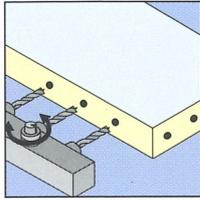

3+1-spindle horizontal drilling head

360° swivel action using the C axis. 32 mm or 20 mm drill spacing. An additional output for a longer tool is provided on the back.

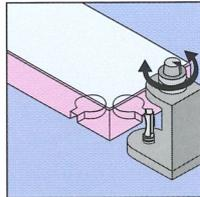
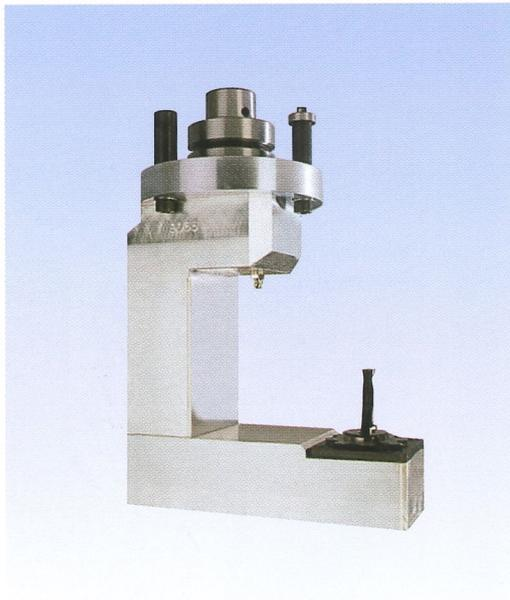
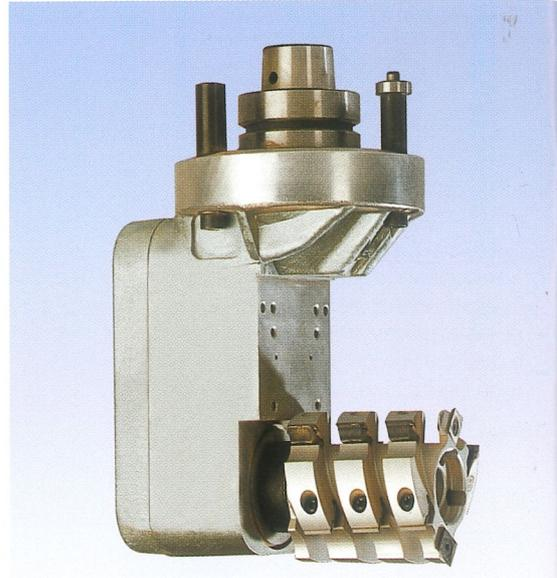

Underfloor trimming unit

For drilling and light trimming work on the underneath of the panel, e.g. for joining work panels perhaps with T-Bolts. Spindle outlet vertically upwards. Max. overhang to workpiece outside edge: 100 mm.

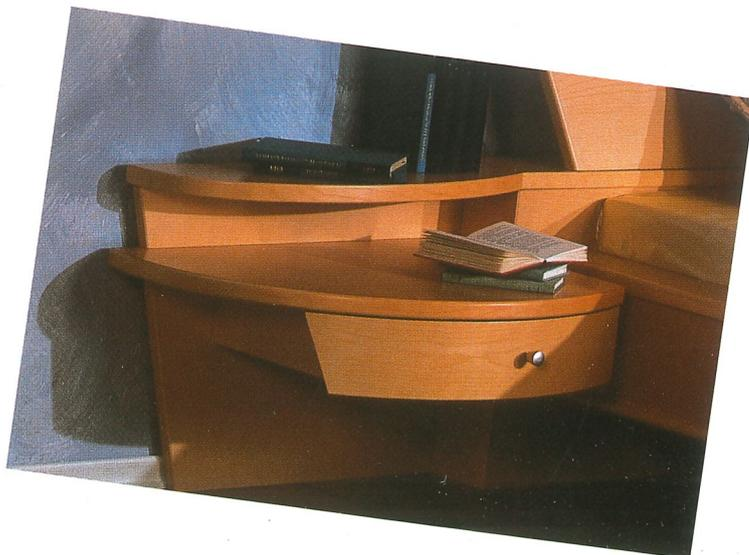
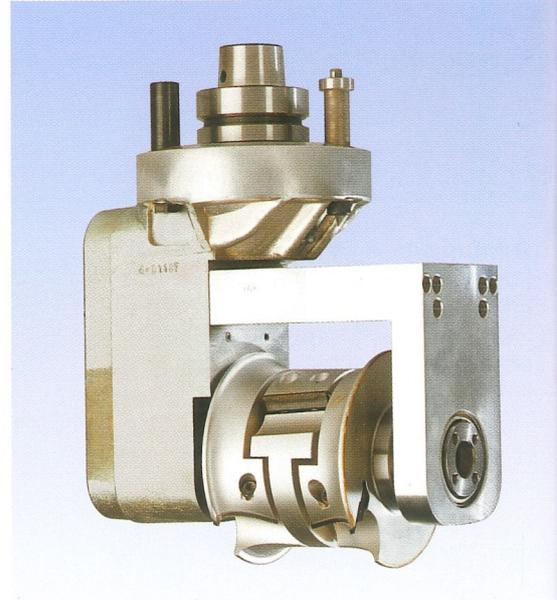

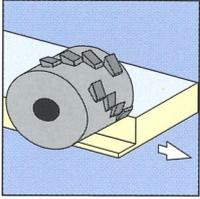

Horizontal routing unit
Angular gear with horizontal shaft to accommodate sawing or routing tools, swivel action using C axis, e.g. for production of stair handrails.

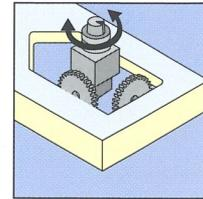
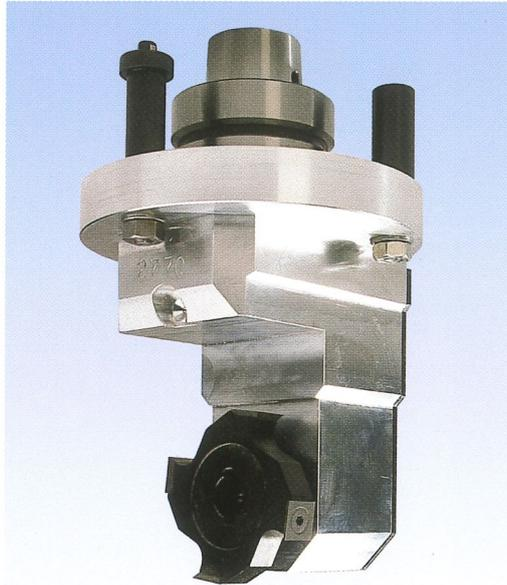

Corner notching unit
To produce right-angled, splinter-free sharp-edged internal corners used for ventilation slots or hardware insertion on worktops.

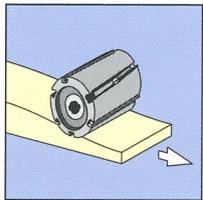

Unit for planer cutter head
For horizontal routing and planing work on the workpiece surface, e.g. solid wood processing, routing of curved parts such as table legs.

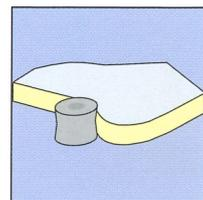
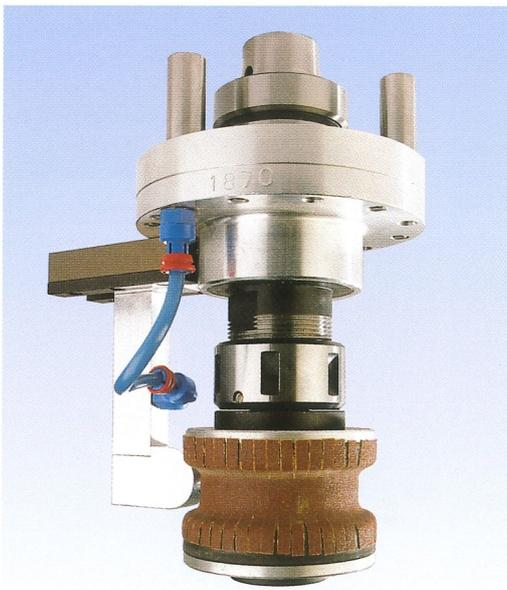

Sanding disk
For sanding work primarily on solid wood edges or MDF panels. The sanding disk are located by means of a DIN collet chuck and continuously cleaned by a jet of compressed air.



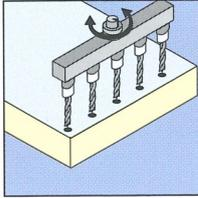

Vertical drilling head

For series hole drilling at any angle with 3, 5 or 7 spindles. Various spacing patterns possible: 25, 30, 32 or 50 mm.

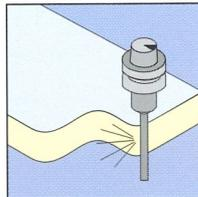

Air jet

For cleaning routed edges of dust and chips for maximum gluing quality.

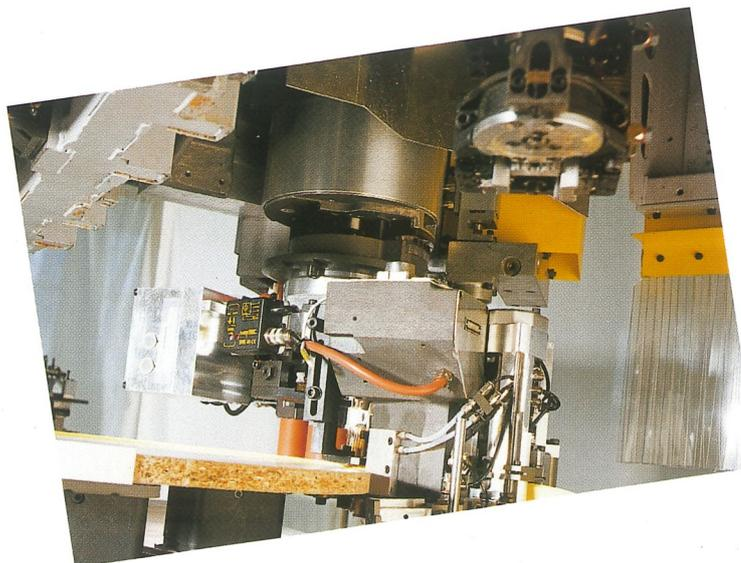

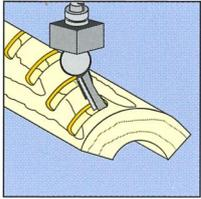

Processing spindle with powered swivel action

For routing and inclined drilling work (5-axis processing). Changable by means of Homag patented electronic interface.

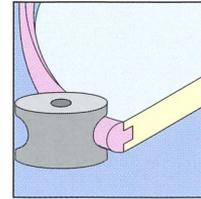
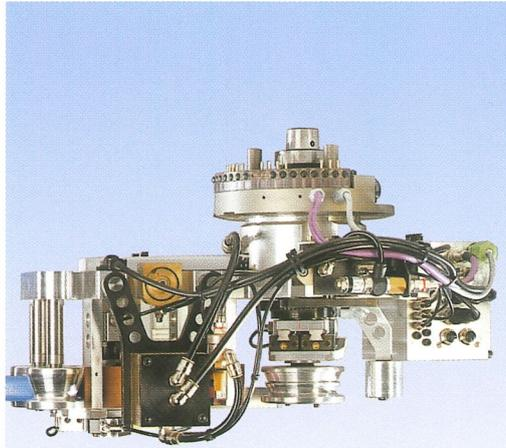

360° T-mold edging unit

Inserted into the main spindle for the automatic insertion of symmetrical edging material with T section into a pre-trimmed groove. Using the C axis for 360° application.

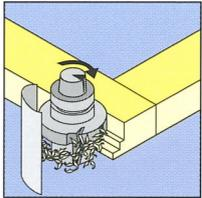

Routing tool retainer with chip guidance

Baffle plate to optimize chip disposal. The chip baffle plate is controlled via the C axis.

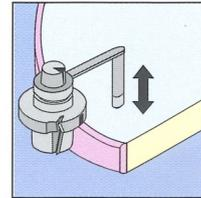

Electronically traced vertical routing unit

For trimming work in the panel surface, on profiles and edges. Automatic, continuous vertical compensation of the workpiece and clamping tolerances. The minimal tracing pressure permits processing of even the most sensitive high-gloss surfaces.

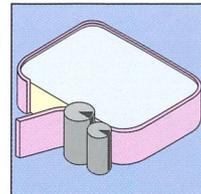
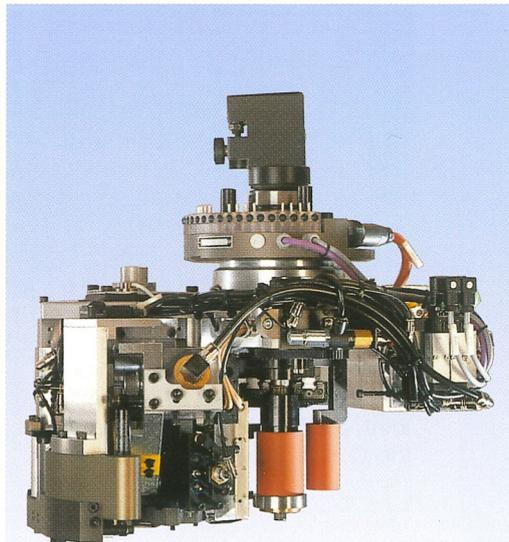

360° gluing unit

360° gluing unit with butt joint for straight edges with direct glue application, melting unit including granulate tank. Shortwave heat lamp to heat thick edges. Unlimited swivel action using the C axis. Optionally with additional hot air jet for minimum workpiece radii from 8 mm (depending on edge type) also for thick edges.

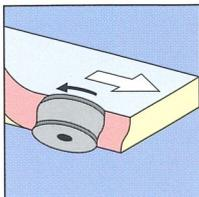
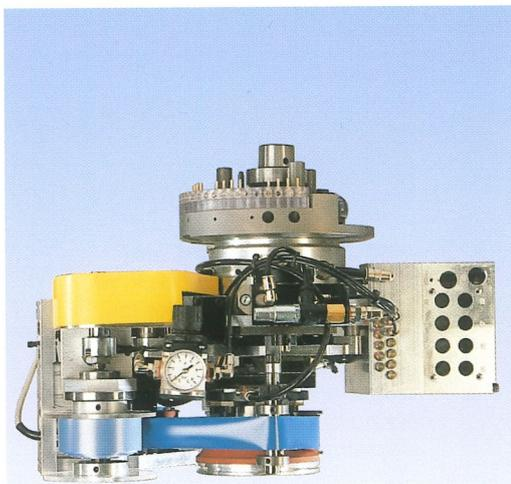

360° transfer finish unit

Inertable into the main spindle from a pick-up station, for application of film onto a suitable substrate material, e.g. MDF. 360° swivel action using the C axis. Suitable for straight edges or symmetrical, slight drum profiles (bull nose).

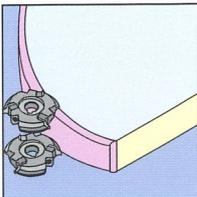
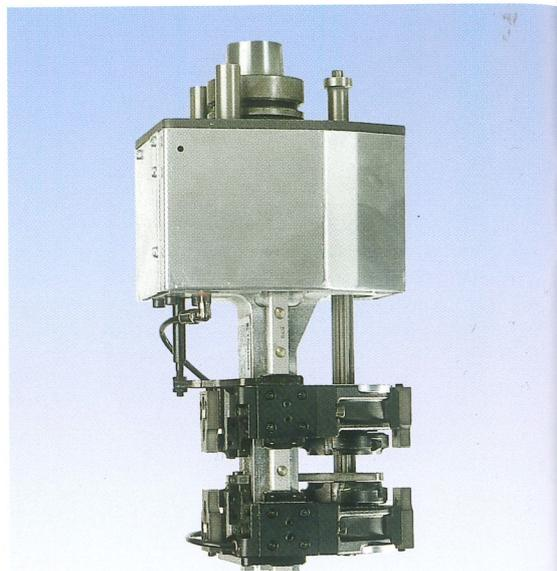

Flush trimming unit

Tracing on three sides, for compensation of workpiece and edge tolerances. Tracing from above, below and the side. The contact pressure is applied at right angles to the workpiece contour. Speed up to max. 12,000 rpm.

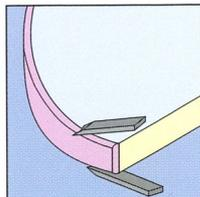

Combination profile / glue joint scraping unit

Simultaneous top and bottom processing of radii in a pre-trimmed PVC edge, removal of glue residues in the area of the glue joint. 360° swivel action using the C axis.

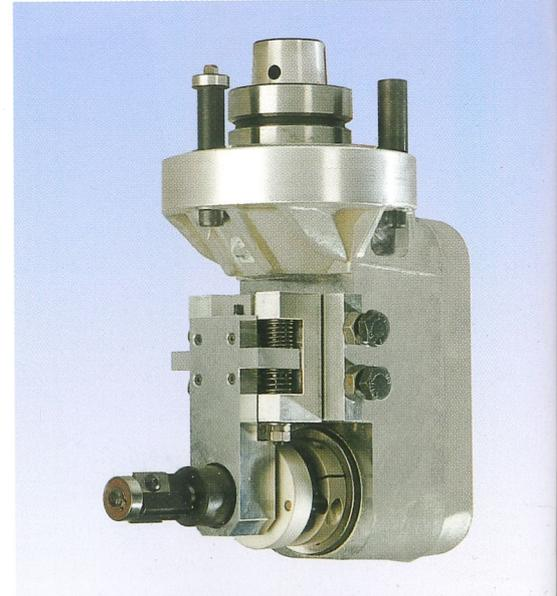
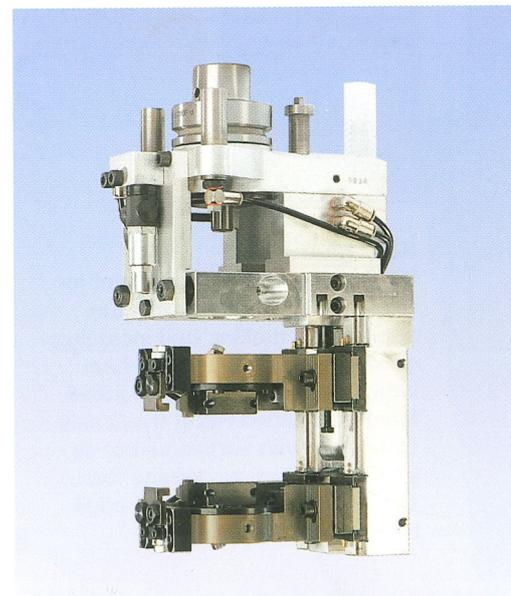

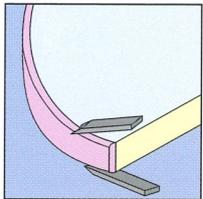
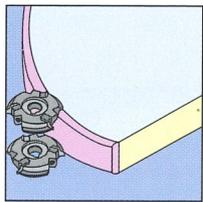

Combination flush trimming / scraping unit

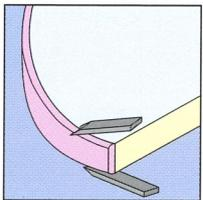

Scraping unit

Tracing on three sides, for compensation of workpiece and edge tolerances. The contact pressure is applied at right angles to the workpiece contour. Available as a glue joint or profile scraping device.

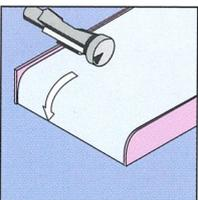

Traced horizontal routing unit

Routing spindle for flush trimming of banded transverse edges on a softforming or postforming profile.

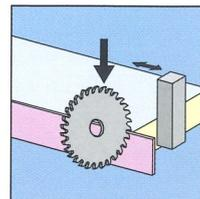
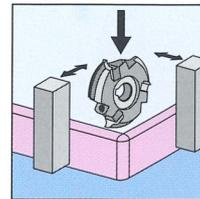
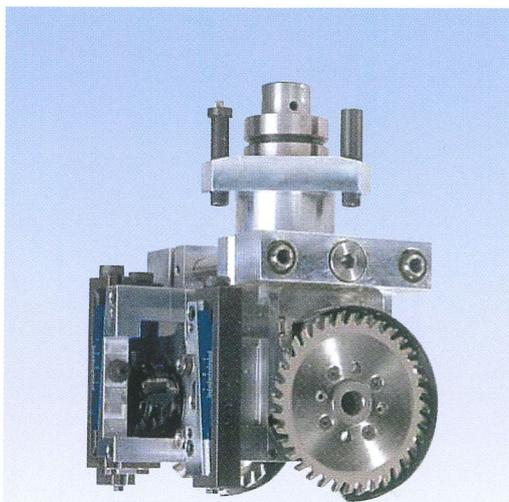

Exclusively from Homag: Traced combination snipping and corner rounding unit

An exclusive, newly developed traced processing unit for ultra-precise snipping and corner rounding. This ingenious new unit simply compensates for workpiece tolerances by CNC trimming and positioning action. The result: Finished components in a unique standard of quality!

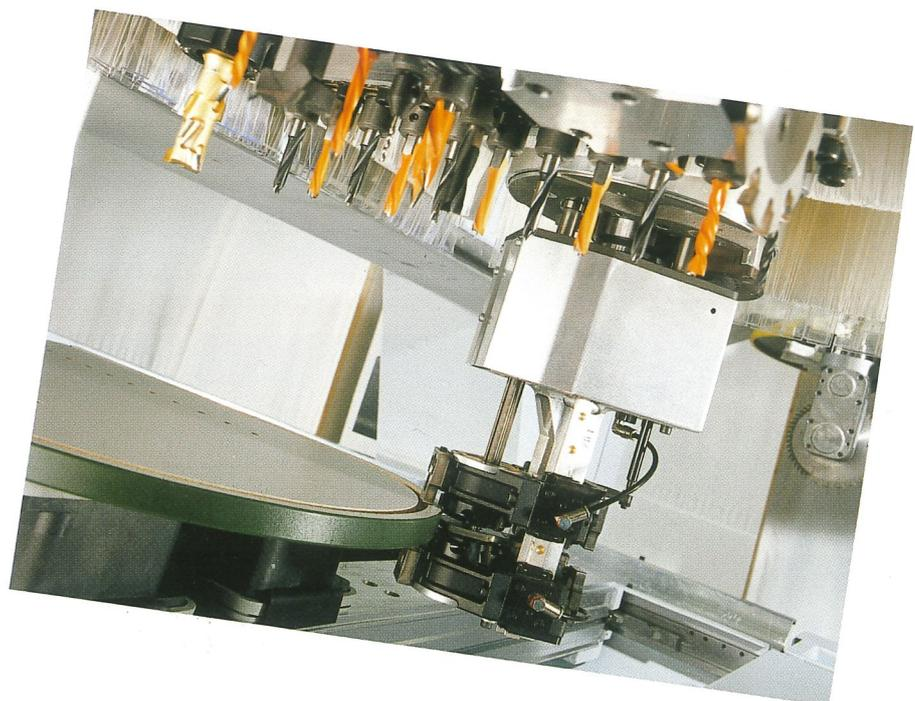

A drilling head capable of more than just vertical drilling

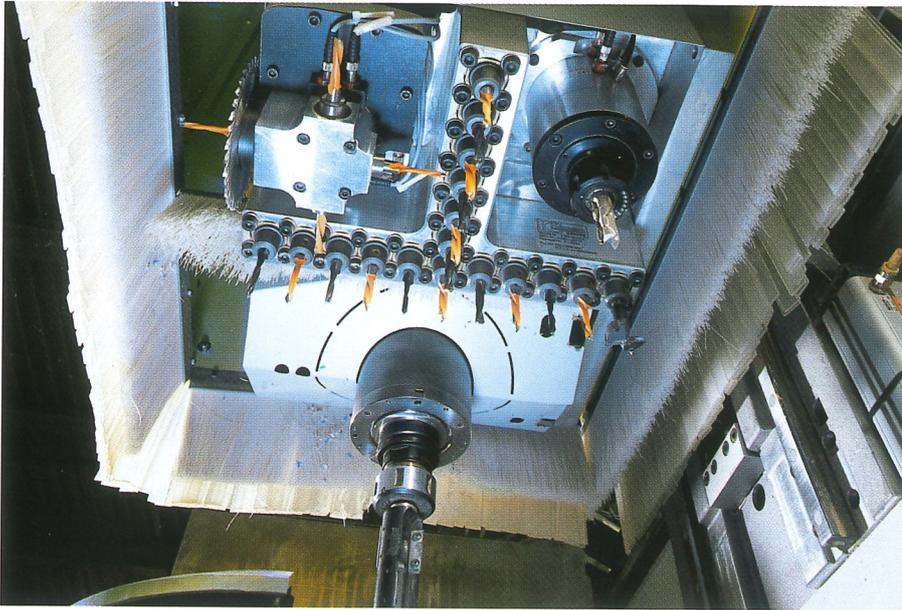

Drilling head with scope for optional upgrading

The modular structure of the drilling head encompasses optionally 12 or 17 spindles. The double spindle bearings are configured to withstand high levels of stress. The attachment of one or two adapter units is also possible. Benefits: More tools can be exchange mounted without the need to change units, or upgrading is possible up to a maximum of 29 spindles.

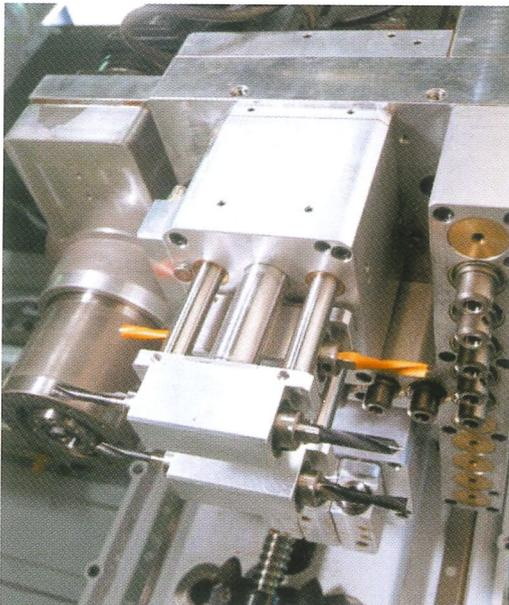

Adapter drilling head

Horizontal with 3 x 2 drilling spindles, with facility for individual accessing of each pair of spindles. For horizontal holes with different diameters or for series holes with 32 mm spacing (available in X or Y).

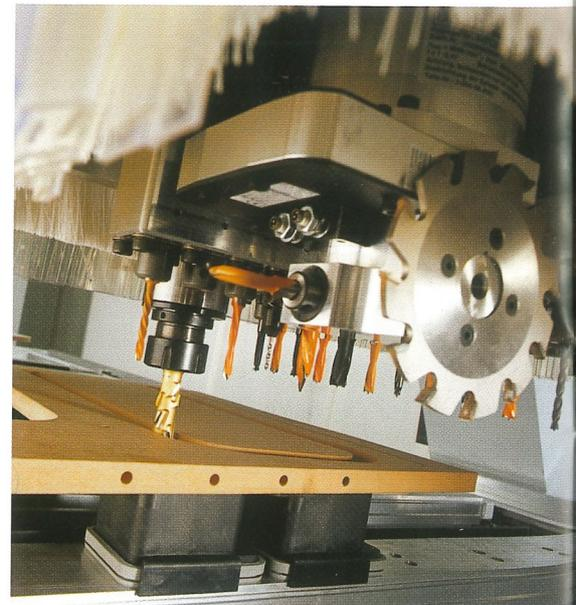



**Adapter drilling unit
4 x drilling + grooving**

Four drills with different diameters for horizontal holes and a circular or grooving saw blade are used without the need for a tool change. Available in two configuration, with rigid grooving saw in X or Y, alternatively with 0/90° swivel action.

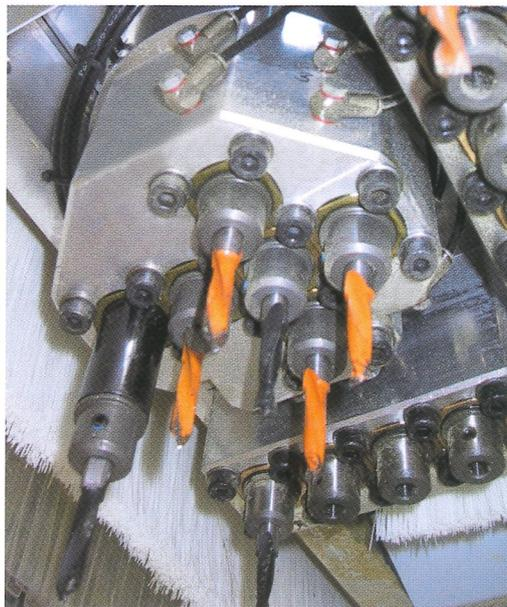

Adapter drilling head

6 vertical spindles with individual actuation capability.

Adapter routing spindle

For deployment of an additional tool without tool changing time. For C-Frame machines with kneetable, the working area is also extended in the Y direction.



Measurement probe

To determine workpiece position data or an actual measurement in X, Y or Z. The data is offset in the control system during further processing.

Clamping elements for knee-type tables

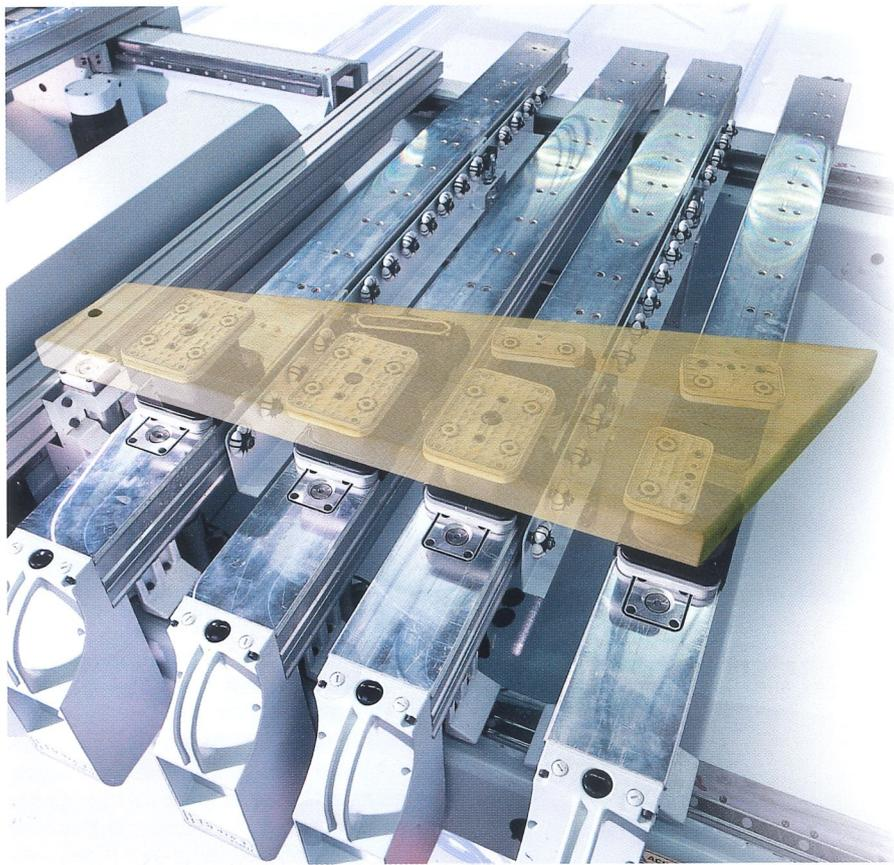

Output increasing by flexible clamping systems

The development of a new exclusive suction cup platform for use with the knee clamping system means it is possible to move a hoseless suction cup along the knee without the need to worry about the integrated suction points. This functional feature is made possible by a system of chambers which suppresses leaks between the suction point and suction cup. The dual-circuit vacuum system permits the suction cup to first be fixed, and then in a second stage, fixture the workpiece. This does away with unwanted movement of the suction cups when workpieces are positioned.



**Vacuum clamp
160 x 115 mm**



**Vacuum clamp
160 x 115 mm
with lift device**





Vacuum clamp
120 x 50 mm
 (available in two versions: 0° or 90°)



Vacuum clamp
130 x 30 mm
 (available in two versions: 0° or 90°)

Vacuum clamp
125 x 75 mm
 (available in two versions: 0° or 90°)



Vacuum clamp
160 x 115 mm
 for templates (height 75 mm)

Vacuum clamp
125 x 75 mm



Exchangeable rubber liner
 for all suction cups

Homag clamping technology – a solution every time



Vacuum clamp
125 x 75 mm
360° rotation

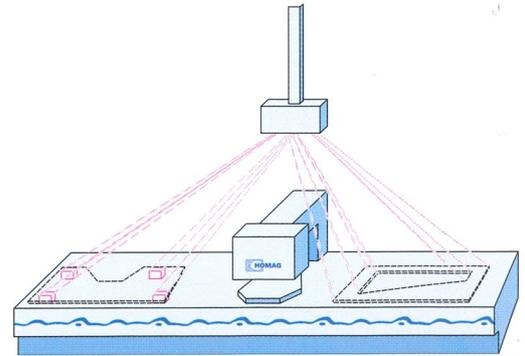

Vacuum clamp
120 x 50 mm
360° rotation

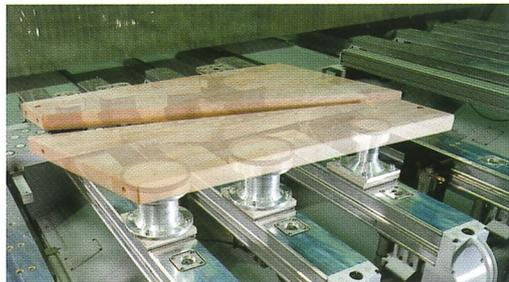

Clamping fixture for steps
Fixture for all-round processing of two steps. After the separating cut, the two steps are moved apart. Different circular suction cups are available as clamping elements with a clamping height of 150 mm.

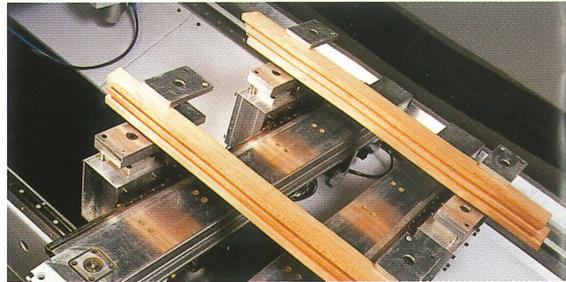

Special suction cups
For clamping arched small components for 5-axis processing.

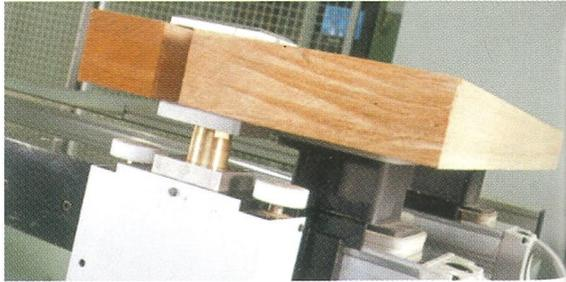
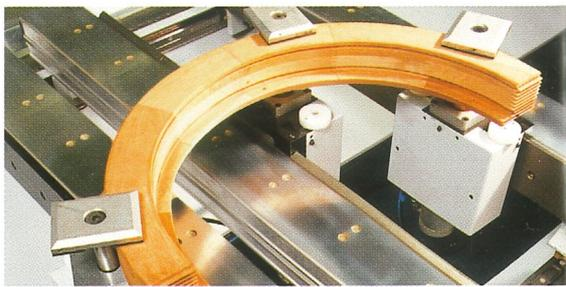

Laser projection

A projection laser is available whose high light intensity ensures an easily visible display even in bright daylight. The laser displays

- the workpiece contour in order to permit easy positioning of workpieces or
- positioning points for the individual clamping elements. In this process, the suction cup position is calculated automatically in woodWOP that it cannot be damaged during processing.

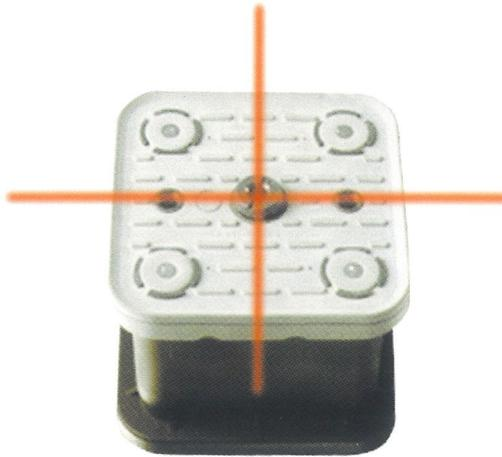

Laser positioning aid

For positioning suction cups

Vacuum clamp

130 x 30 mm
360° rotation



Stop bolt for coating ply overhang

Coated workpieces can be positioned by means of a lift-and-turn fixture.

Automatic window clamping fixture

Clamping system for four-sided processing of window staves without the need for manual reclamping. The clamping elements can be lowered and do not need to be removed for processing panel-shaped workpieces.



Knee extension

For extension arm machines with additional suction cups (height = 50 mm).

3-step clamping system

Clamping elements with integrated support cylinders and insertion aid for wide staves. Can be used for processing straight and curved workpieces also in conjunction with vacuum clamps.



Clamping fixture for uprights and staves

Clamping element with adjustable clamping jaws for clamping e.g. staircase uprights, staves and handrails.

Combined deployment of the **3-step window clamping system** and suction cups.



Clamping system for arched components

Comprising a clamping rail and a pneumatic clamping element.

Homag – the home of innovation

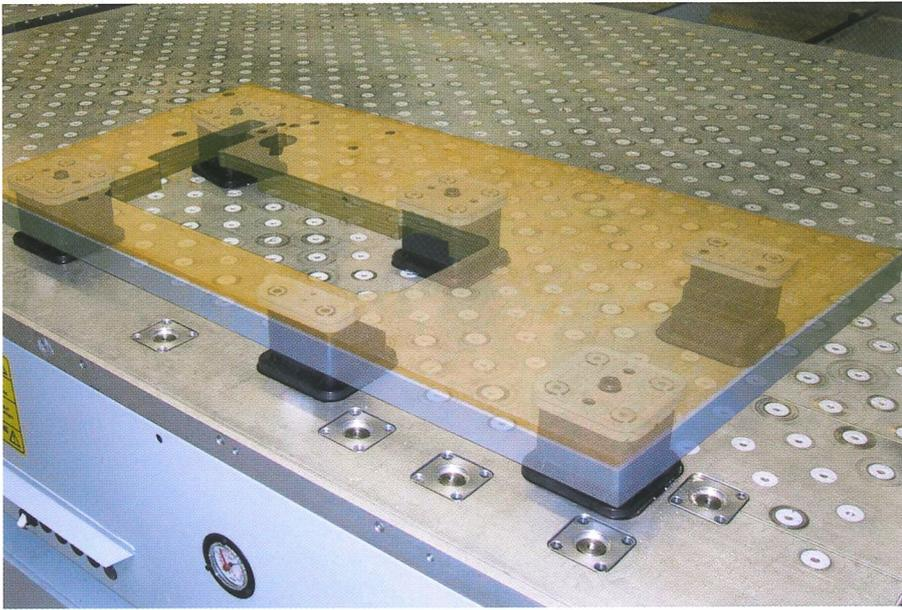

Flexible solution: The GA table

The GA table features a hoseless vacuum system with solenoid valves. The vacuum is created by two low air pressure stages and is used to suction the vacuum clamps to the GA table and the workpiece to the suction cups. Each individual suction cup can be individually positioned. The smooth surface of the table allows the easy removal of waste pieces. The extensive clamping element catalogue opens up scope for wide-ranging applications. GA – the innovative table version exclusively from Homag.

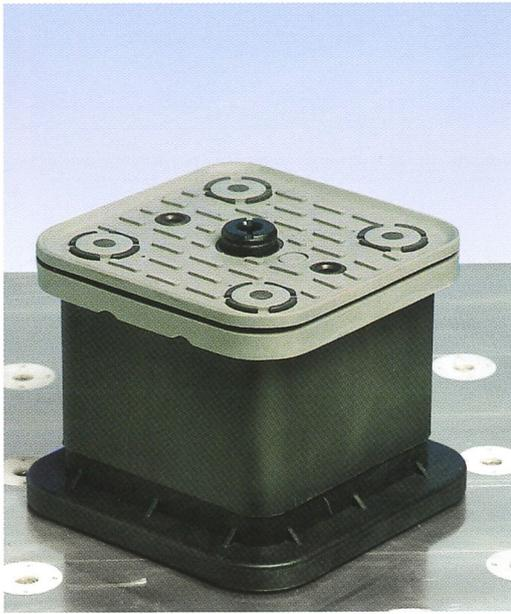

**Vacuum clamp
120 mm with
lift device**



**Vacuum clamp
120 x 120 mm**

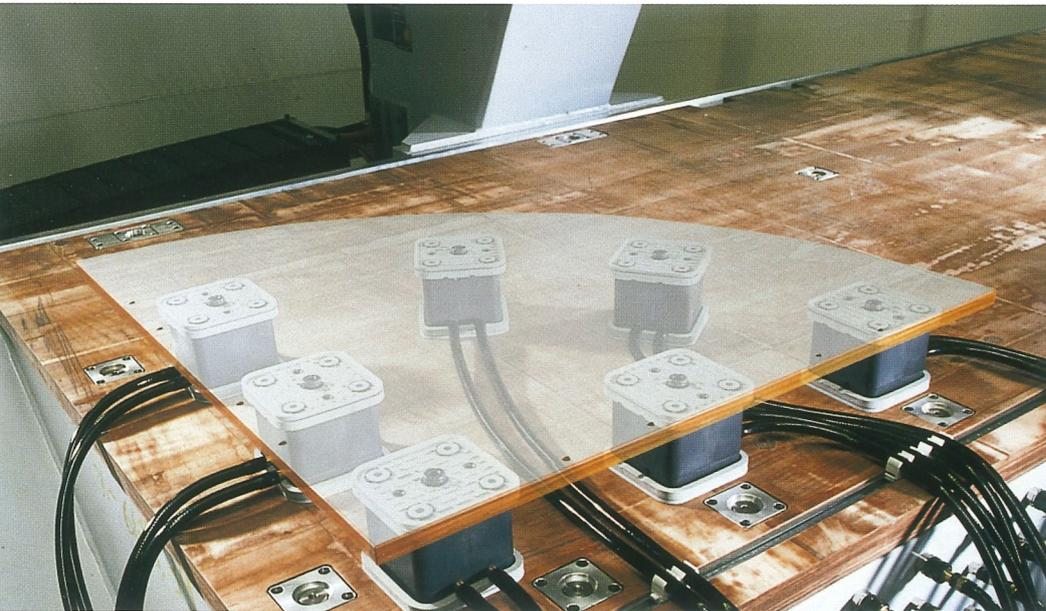

G table

The low-cost variant comprising stabil hose system to transmitting the vacuum. The same suction forms are available as for the GA-table (see page 18).

**Vacuum clamp
120 x 75 mm**

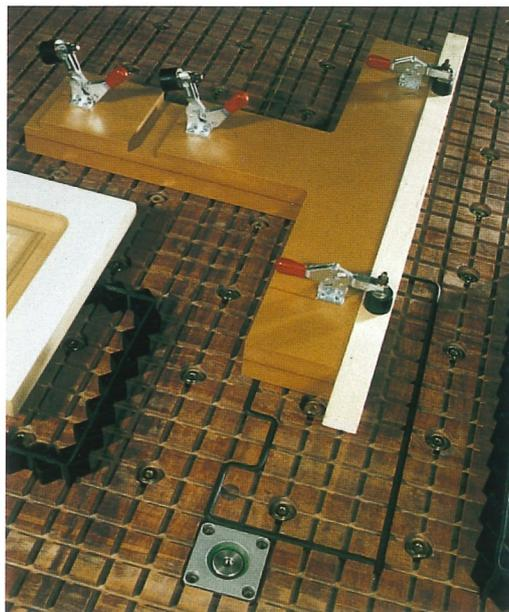

**Low cost entry-level solution:
The grid-type table**

This table version permits precise, flexible adjustment of the vacuum suction surface to the contours of the workpiece: With the sealing gasket version, the entire workpiece surface makes flush contact with the table. The optional plug-in module suspends the clamped workpiece 20 mm above the grid table to allow for processing beyond the panel bottom. Stop bolts or fences (optional) are available to provide precise workpiece positioning on the work table.

**Vacuum clamp
125 x 50 mm**



Vacuum clamp (grid-table)

For insertion into the grooves or on a spoil board (200 x 170 x 36 mm or 170 x 80 x 36 mm).



A member of the Homag Group



Homag Holzbearbeitungssysteme AG

Homagstraße 3-5
72296 SCHOPFLOCH
GERMANY

Tel.: +49 (74 43) 13-0
Fax: +49 (74 43) 13 23 00
E-Mail: info@homag.de
Internet: www.homag.de

